



Description

PJEZ* represents a range of electronic microprocessor controllers with LED display developed for the management of refrigerating units, display cabinets and showcases; are designed for the management of static refrigerating units (no fan on the evaporator) operating at temperatures above 0°C.

Technical specifications

- Electronic controllers for normal temperature static refrigeration units
- Power supply 230Vac
- Ambient probe NTC
- Compressor relay 16A

Dimensions (mm)

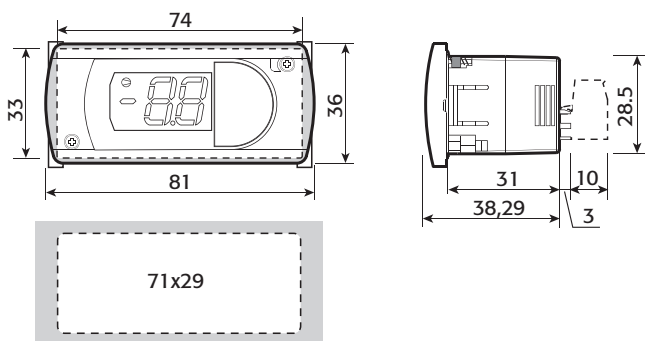

Fig.1

Panel mounting

Front (with 2 screws ø 2,5x12 mm)

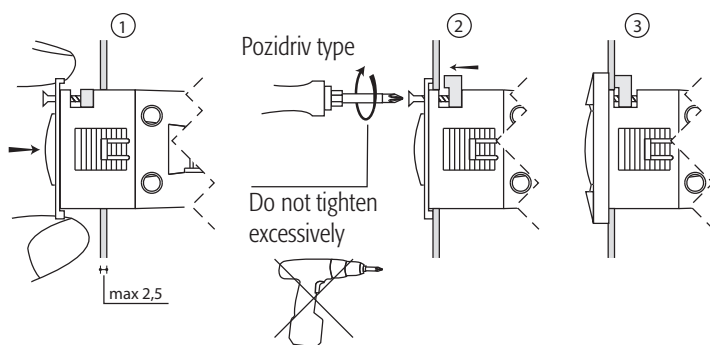

Fig.2

Rear (with 2 quick-fit side brackets)

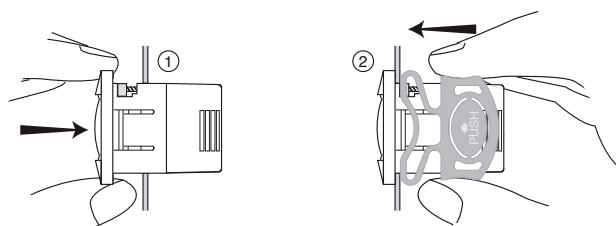

Fig.3

If necessary, remove the covers to simplify wiring

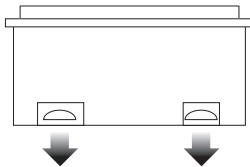

Fig.4

Electrical connections

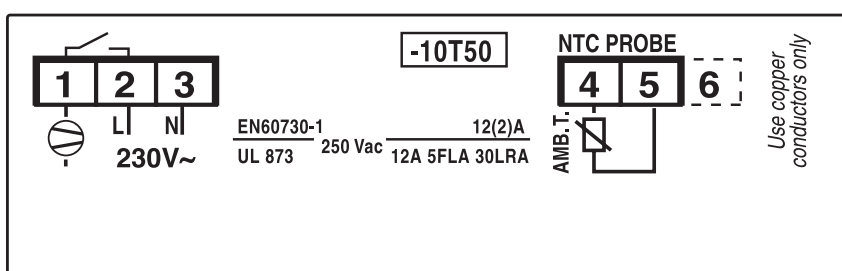

Fig.5

Display and functions

During normal operation, the controller displays the value of the temperature read by probe. In addition, the display has LED that indicate the activation of the control functions (see Tab. 1), while the 3 buttons can be used to activate/deactivate some of the functions (see Tab. 2).

Compressor LED signals

icon	function	normal operation			start up
		ON	OFF	blink	
	compressor status	on	off	ON request in progress	ON

Tab. 1

Table of functions activated by the buttons

button	normal operation	start up
	more than 3 s: toggle ON/OFF	-
	more than 3 s: start/stop defrost	for 1 s display firmware vers. code
	- 1 s.: display/set the set point - more than 3 s: access parameter setting menu (enter password '22')	for 1 s RESET current EY set

Tab. 2

Setting the setpoint (desired temperature)

Step	Action	Effect	Meaning
1	Keep SET button pressed for 2 s	After 1 sec currently setpoint value will flash on display	It's regulation setpoint currently active
2	Press UP or DOWN buttons	Setpoint value will change	Set desired value
3	Press SET button	Controller will visualize temperature read by probes again	setpoint is modified and saved

Accessing and setting the parameters

Step	Action	Effect	Meaning
1	Keep SET button pressed for 3 s	After 3 s display will visualize "PS"	Password is requested
2	Press SET button again	Display will visualize "0" blinking	
3	Press UP or DOWN button	Visualized value on display will change	Insert password "22"
4	Press SET button	After 5 s the first parameter, "/5", will be visualized on display	It's the name of the first parameter
5	Press UP or DOWN button	Parameter list will be scrolled on display (refer to Table of parameters)	Select desired parameter
6	Press SET button	Display will visualize value of the selected parameter	It's the currently parameter value
7	Press UP or DOWN button	Parameter value visualized on display will change	Set desired value
8	Press SET button	Display will visualize parameter name again	Attention: parameters updating is not yet active
9	Repeat steps 5, 6, 7 and 8 for all desired parameters		
10	Keep SET button pressed for 5 s	Controller will visualize temperature read by probes again	Attention: now parameters updating will be active

Table of parameters

	Parameter	Min.	Max.	Def.	UOM
PS	PASSWORD	0	99	22	-
/	PROBE PARAMETERS				
/5	Select °C / °F (0 = °C; 1 = °F)	0	1	0	-
/6	Disable decimal point (1 = disabled)	0	1	0	-
/C1	Probe calibration (OFFSET)	-50.0	50.0	0.0	°C/°F
r	CONTROL PARAMETERS				
St	Setpoint (control temperature)	-50.0	90.0	3.0	°C/°F
rd	Control differential (hysteresis)	0.0	19.0	2.0	°C/°F
c	COMPRESSOR PARAMETERS				
c0	Comp. and fan start delay after start-up	0	100	0	min
c1	Min. time between successive comp. starts	0	100	1	min
c4	Compressor safety (duty setting)	0	100	15	min
d	DEFROST PARAMETERS				
d0	Type of defrost (0 and 1= defrost by temperature; 2, 3 and 4= defrost by time)	0	4	2	-
d1	Interval between defrosts	0	199	6	h/min
dP	Max. or effective defrost duration	1	199	20	min/s
d4	Defrost when the instrument is switched on (1= activated)	0	1	0	-
d6	Disable temperature display during defrost (1= display disabled)	0	1	1	-
A	ALARM PARAMETERS				
A0	Alarm differential	-20.0	20.0	-2.0	°C/°F
AL	Low temperature alarm threshold/deviation	-50.0	250.0	-5.0	°C/°F
AH	High temperature alarm threshold/deviation	-50.0	250.0	15.0	°C/°F
Ad	Low and high temperature alarm delay	0	199	0	min
H	OTHER SETTINGS				
H2	Enable keypad 0= keypad disabled 1= keypad enabled 2= keypad enabled except for ON/OFF function	0	2	1	-
EY	Restore the Default settings	0	1	0	-

Table of alarms

Alarm code	Description	Parameters involved
E0	probe 1 error= control	-
LO	low temperature alarm	[AL] [Ad]
HI	high temperature alarm	[AH] [Ad]
EE	unit parameter error	-
EF	operating parameter error	-
dF	defrost running	[d6=0]
Pd	defrost awaiting execution	-

How to restore the Default settings (refer to table of parameters in this sheet)

- 1) Access parameter EY (entering password 22 and scroll parameter list).
- 2) Select the desired configuration:
 - EY = 0 → No changes;
 - EY = 1 → Restore of default settings (refer to Table of parameters in this sheet);
- 3) Exit the setting procedure (holding SET button for more than 3 s).
- 4) Power off the device and then power it on again while holding SET button.
- 5) The display shows "CE" to indicate that the configuration has been restored.

Switching the device ON/OFF

Press UP for more than 3 s. The control and defrost algorithms are now disabled and the instrument displays the message "OFF" alternating with the temperature read by the set probe.

Manual defrost

Press DOWN for more than 3 s (the defrost starts only if the temperature conditions are valid).

Continuous cycle

Press UP and DOWN together for more than 3 s.

Technical specifications

power supply	230 V 1~, -10% +15% 50/60 Hz
rated power	3 W
input	NTC probe
relay output	16 A relay UL: 12 A resistive 5 FLA, 30 LRA 240 Vac 30,000 cycles EN60730-1: 12(2)A or 10(4)A (N.O. only) 250 Vac 100000 cycles;
type of probe	Std CAREL NTC 10 KΩ at 25 °C
power supply/ relay output connector	- screw terminals pitch 5mm for cables with cross-sect. from 0.5 mm ² to 1.5 mm ² ; 12 A max;
probe connector	screw terminals: - 2-pin pitch 5mm for models with 1 probe (cable cross-section from 0.5 mm ² to 1.5 mm ²); 12 A max;
assembly	using screws from the front or with brackets at the rear
display	LED display, 2 digits plus sign, decimal point and compressor icon
keypad	3 buttons with membrane
operating conditions	-10T50 °C - humidity <90% rH non-condensing
storage conditions	-20T70 °C - humidity <90% rH non-condensing
range of measurement	-50T90 °C (-58T194 °F) - resolution 0.1 °C/°F
front panel index of protection	panel installation with IP65 type 1
case	plastic terminal, 81x36x38 mm
classification according to protection against electric shock	Class II
environmental pollution	II
PTI of the insulating material	250 V
period of stress across the insulating parts	long
category of resistance to heat and fire	category D (UL94 - V0)
immunity against voltage surges	category 1
type of action and disconnection	micro-disconnection 1C
no. of relay automatic operating cycles	EN60730-1: 100,000 cycles UL: 30,000 cycles (250 Vac)
software class and structure	Class A
cleaning the instrument	Only use neutral detergents and water.
cable max. length	serial: 1 km probes: 30 m relay: 10 m

Note: do not run the power cable less than 3 cm from the bottom part of the device or from the probes; **for the connections only use copper wires.**

Safety standards

compliant with the relevant European standards. Installation precautions:

- the connection cables must guarantee insulation up to 90 °C;
 - for 12 Vac versions use Class II transformers. To ensure compliance with the immunity standards (surge), the transformer must be one of the models specified (see the CAREL price list). For the 12 Vac/dc versions, as double insulation cannot be guaranteed between the power supply and the relay outputs, only use safety low voltage loads (up to 42 V effective rated value);
 - ensure a space of at least 10 mm between the case and the nearby conductive parts;
 - digital and analogue input connections less than 30 m away; adopt suitable measures for separating the cables so as to ensure compliance with the immunity standards;
- Secure the connection cables of the outputs so as to avoid contact with very low voltage parts.

IMPORTANT WARNINGS

The CAREL product is a state-of-the-art device, whose operation is specified in the technical documentation supplied with the product or can be downloaded, even prior to purchase, from the website www.carel.com. The customer (manufacturer, developer or installer of the final equipment) accepts all liability and risk relating to the configuration of the product in order to reach the expected results in relation to the specific final installation and/or equipment. The failure to complete such phase, which is required/indicated in the user manual, may cause the final product to malfunction; CAREL accepts no liability in such cases. The customer must use the product only in the manner described in the documentation relating to the product. The liability of CAREL in relation to its products is specified in the CAREL general contract conditions, available on the website www.carel.com and/or by specific agreements with customers.



WARNING: separate as much as possible the probe and digital input signal cables from the cables carrying inductive loads and power cables to avoid possible electromagnetic disturbance. Never run power cables (including the electrical panel wiring) and signal cables in the same conduits.



Disposal of the product

The appliance (or the product) must be disposed of separately in accordance with the local waste disposal legislation in force.

CAREL reserves the right to modify the features of its products without prior notice.

CAREL

CAREL INDUSTRIES HQs

Via dell'Industria, 11 - 35020 Brugine - Padova (Italy)

Tel. (+39) 0499716611 - Fax (+39) 0499716600 - <http://www.carel.com> - e-mail: carel@carel.com

+050004121 - rel. 1.0 - 19.10.2009